

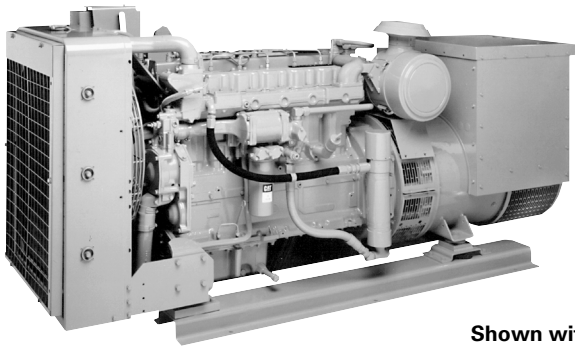

Marine Generator Set 3306B

190 kW (238 kVA) 60 Hz @ 1800 rpm



Shown with Accessory Equipment

CATERPILLAR ENGINE SPECIFICATIONS

I-6, 4-Stroke-Cycle-Diesel

- Emissions IMO compliant
- Displacement 10.5 L (641 cu. in.)
- Bore 120.7 mm (4.75 in.)
- Stroke 152.4 mm (6.0 in.)
- Aspiration Turbocharged-Aftercooled
- Governor Hydra-mechanical or PSG
- Engine Weight, Net Dry (approx)
 - Heat Exchanger Cooled 1882 kg (4150 lb)
 - Keel Cooled 1860 kg (4100 lb)
- Capacity for Liquids
 - Cooling System (engine only) . . . 15.9 L (4.2 U.S. gal)
 - Lube Oil System (refill) 38.8 L (10.25 U.S. gal)
- Oil Change Interval 250 hr
 - Caterpillar DEO 10W30 or 15W40
- Rotation (from flywheel end) Counterclockwise

STANDARD EQUIPMENT

- Air Inlet System**
 - Regular duty air cleaner, rain cap
- Charging System**
 - 24V 35 Amp alternator
- Cooling System**
 - Gear driven, self priming, centrifugal auxiliary sea water pump with rubber impeller (heat exchanger engines); gear driven centrifugal jacket water pump; oil cooler, engine-mounted heat exchanger with removable tube bundle and replaceable copper-nickel tubes (heat exchanger engines); expansion tank; thermostat and housing
- Exhaust System**
 - Watercooled manifold and turbocharger; dry elbow and flange, 127 mm (5 in.)
- Flywheel and Flywheel Housing**
 - SAE No. 1 (156 teeth)
- Fuel System**
 - Fuel priming pump, fuel transfer pump, fuel filter, primary fuel filter, flexible fuel lines
- Generator and Attachments**
 - Brushless PM excited SR4 generator, VR3 voltage regulator, 500 watt space heater
- Instruments**
 - RH instrument panel with oil pressure, water temperature, and fuel pressure gauges; service meter
- Lube System**
 - Top-mounted crankcase breather, oil filter, LH oil level gauge, oil pan
- Mounting System**
 - Rails, 85 mm (3.3 in.) high with 20.5 mm (0.8 in.) mounting holes; linear vibration isolators between base and generator
- Starting System**
 - 24V electric starting motor
- General**
 - Vibration damper and guard, Caterpillar yellow paint, lifting eyes

ACCESSORY EQUIPMENT

- Air Starting Motor
- Alarm Contactor — Oil Pressure, Water Temperature
- Auxiliary Drive Pulley
- Digital Tachometer
- Double Wall Fuel Lines and Drain
- 12V Electric Gauges — Oil Pressure, Water Temperature
- 24V or 32V Electric Gauges — Oil Pressure, Water Temperature
- Electric Shutoffs — Oil Pressure, Water Temperature, Overspeed
- Ether Starting Aid
- Exhaust Elbow, Pipe, Flexible Fittings
- Extension Terminal Box
- Fuel Ratio Control
- Hydraulic Pump Drive
- Low Voltage Connections
- Magnetic Pickup
- Manual Shutoff Lever
- Manual Voltage Control
- Mechanical Tachometer Drive
- Mechanical Overspeed Contactor
- Paralleling Kit
- RFI Filter
- RH Oil Level Gauge
- Solenoid Shutoff — 12V or 24V, ETR or ETS
- Spare Parts Kit
- Terminal Strip Connections

PERFORMANCE DATA

Turbocharged-Aftercooled

DM4994-00

190 kW (.8 pf) 238 kVA			
% load	ekW	Lph	gph
100	190	54.0	14.3
75	143	40.7	10.8
50	95	27.6	7.3
25	48	15.8	4.2

